



VER 1.2

Technical Manual

DS-OL57-IRS4



Table of Contents

1. Product Introduction.....	3
1.1 Features.....	3
1.2 Technical Parameters.....	3
1.3 Dimensional Drawing.....	3
2. Schematic and Interface Definition.....	4
2.1 Power Input.....	4
2.2 Signal Input.....	4
2.3 Indicator Function.....	5
3. Typical Signal Connection.....	5
3.1 High Speed Input Port.....	5
3.2 Input Signal of Switch or Relay Connection.....	6
3.3 Connection of Input Signal and NPN Type Output.....	7
3.4 Connection of Input Signal and PNP Type Output.....	7
4. Control Parameter.....	7
4.1 Controller Basic Status (Class 01).....	7
4.2 Basic Parameter Setting (Class 02).....	8
4.3 Control Parameters (Class 04).....	8
4.4 Input Block Designation (Class 05).....	10
5. Appendix.....	11
5.1 Alarm Code.....	11

1. Product Introduction

1.1 Features

- Input power : DC 24 - 48V
- Output rated current (peak value) : 5.6 A / Phase
- Pulse, support MODBUS RTU communication protocol, I/O trigger control, Internal programming
- Protection function : Current over, Voltage over, Under voltage

1.2 Technical Parameters

Drive model		DS-OL57-IRS4
Adapted motor		Suitable for two-phase hybrid stepping motor
Power supply		DC 24V ~ 48V
Output current		Max. rated current 5.6A/phase (peak)
Drive way		Full-bridge bipolar PWM drive
Input signal	IN1 (pulse) signal	Optocoupler input voltage: H = 3.5 - 26V, L = 0 - 0.8V
	IN2 (direction) signal	On current 5 ~ 8mA
	IN3 (offline) signal	Optocoupler input voltage: H = 3.5 - 5V, L = 0 - 0.8V
	IN4 (alarm clear) signal	On current 5 ~ 8mA
		Signal power supply 12VDC series resistance R = 1 KΩ Signal power supply 24VDC series resistance R = 2.2 KΩ Depending on the input signal voltage, such as a 12V or 24V fix
Output signal		Photoelectric isolated output, withstand voltage up to 30VDC, maximum saturation current 10mA
Device initialization time		2s
Working Environment	Precaution	Avoid dust, oil mist and corrosive gases
	Humidity	< 85 % RH, Non-condensing
	Temperature	0°C - +40°C
	Cooling	Installation in a ventilated environment

1.3 Dimensional Drawing

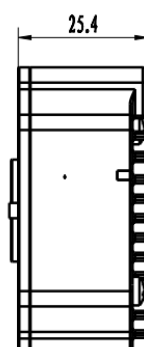
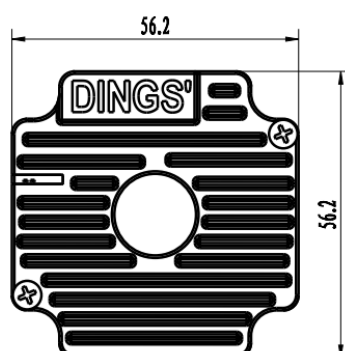

Unit : mm

2. Schematic and Interface Definition

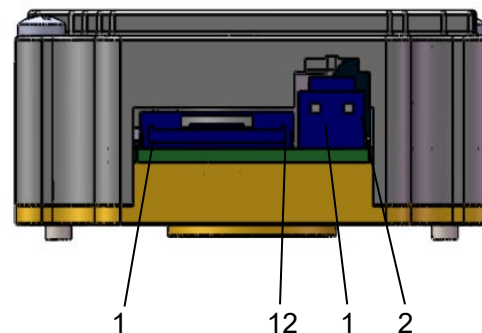

2.1 Power Input (as shown, arranged from left to right)

Pin	Name	Description
1	V+	24V – 48VDC
2	GND	Power supply ground

2.2 Signal Input (as shown, arranged from left to right)

Pin	Name	Description
1	IN1+	External pulse mode : Pulse Internal pulse mode : Universal input port 5 -24V effective, Max. input frequency 500KHz, signal definition configurable
2	IN1-	
3	IN2+	External pulse mode : Direction Internal pulse mode : Universal input port 5 -24V effective, Max. input frequency 500KHz, signal definition configurable
4	IN2-	
5	COMIN	Single-ended input signal common Both positive and negative (5VDC) compatible
6	IN3	External pulse mode : Offline Internal pulse mode : Universal input port, 5V effective Max. input frequency 1KHz, signal definition configurable
7	IN4	External pulse mode : Alarm clear Internal pulse mode : Universal input port, 5V effective Max. input frequency 1KHz, signal definition configurable
8	OUT+	Optoelectronic isolated output, max. voltage 30VDC, max. saturation current 10 mA
9	OUT-	
10	485-GND	485 Communication Port
11	485-A	
12	485-B	

2.3 Indicator Function

This product has 2 red and green LEDs to indicate the light display status:

2.3.1 Status Indication :

Status function	Green light	Description
Stopping	flicker	On, the motor is phase locked but the motor is not running
In operation	Always on	Drive is running
Enable disconnect	flicker	Enable disconnect, motor can be free

2.3.2 Error Indication :

Alarm function	red light	Description
Motor overcurrent	1 green +1 red	Motor phase current overcurrent or drive failure
Motor phase loss	1 green +2 red	Motor is not connected
Overvoltage	1 green +3 red	Power input is greater than 52V
Undervoltage	1 green +4 red	Power input is less than 18V
Other alarms	1 green +5 red	

3. Typical Signal Connection

3.1 High Speed Input Port

Common positive connection

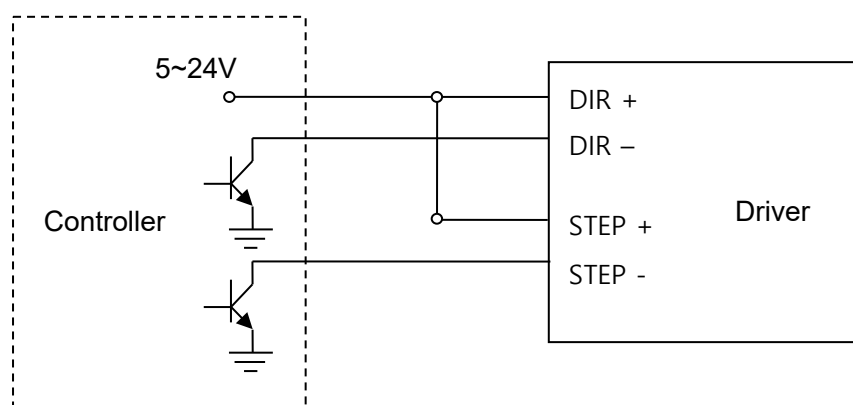

Common negative connection

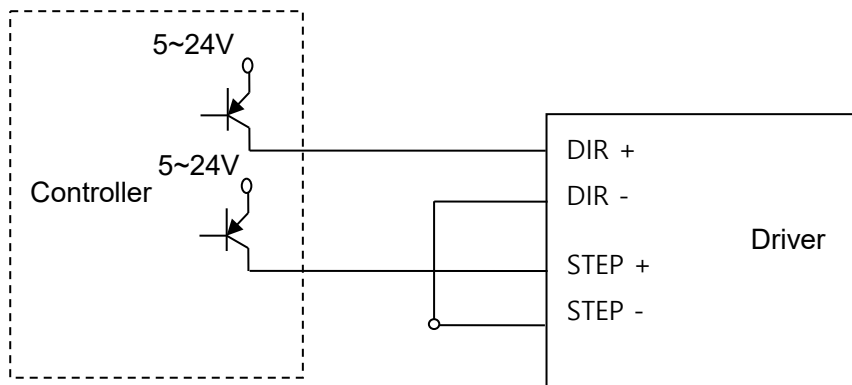

3.2 Input Signal of Switch or Relay Connection

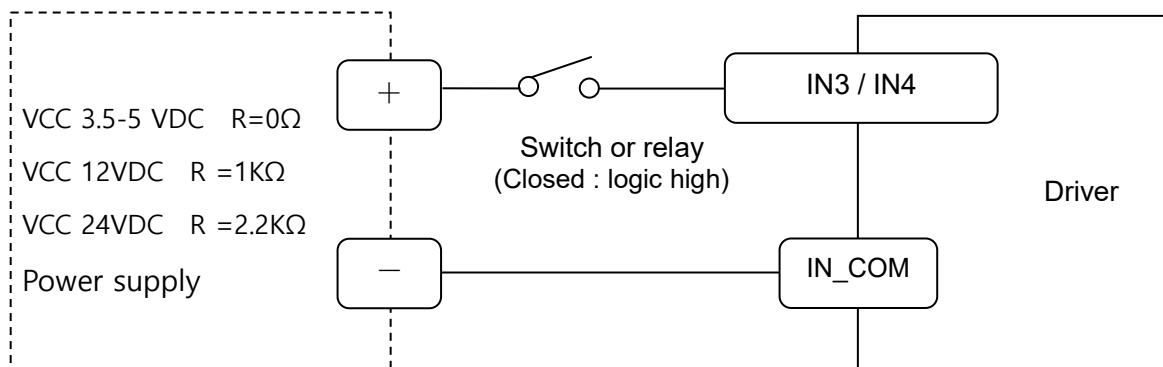
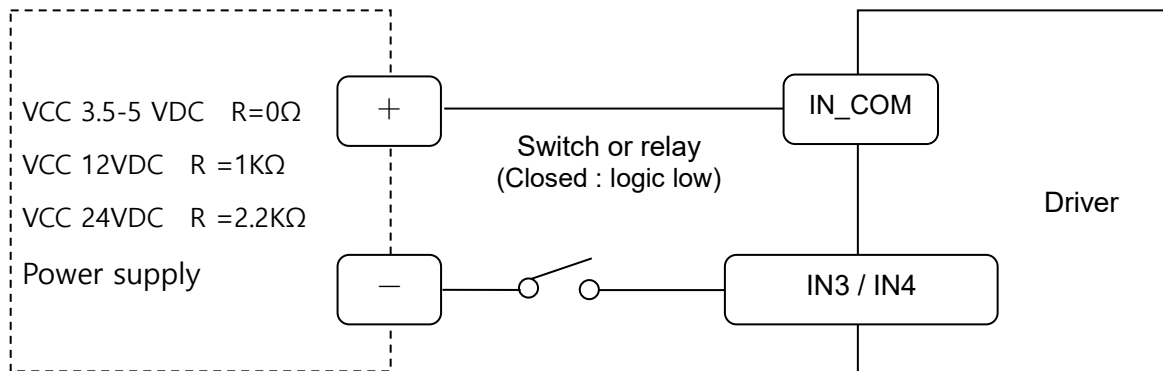

3.3 Connection of Input Signal and NPN Type Output

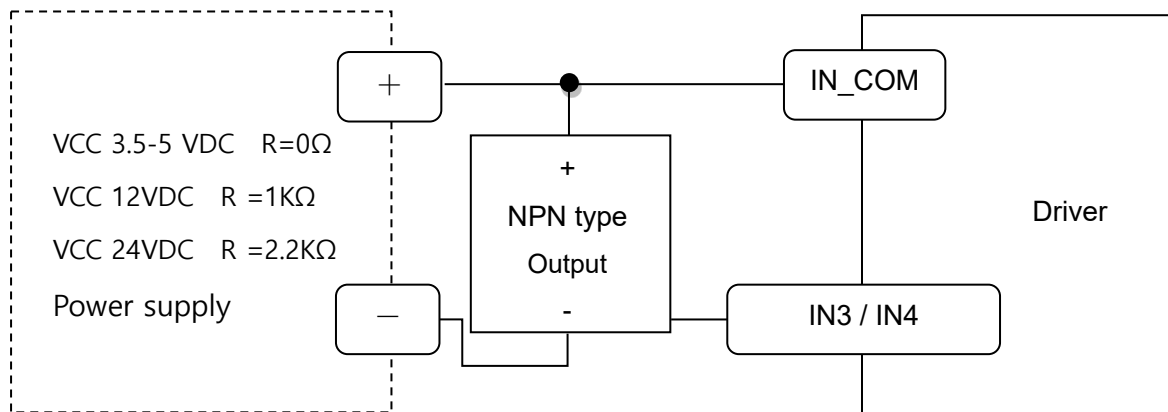

3.4 Connection of Input Signal and PNP Type Output

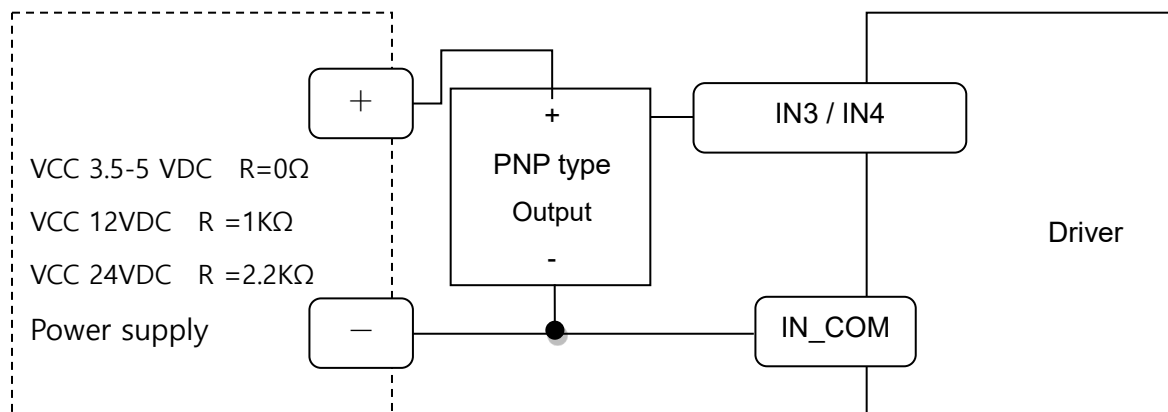

4. Control Parameter

4.1 Controller Basic Status (Class 01)

adr	word	content	Elaborate	Range / unit
0100	1	Motor current	Motor real-time current value	0.1%A
0101	1	Input voltage	Current input voltage	1%V
0104	2	Set up segmentation	Set segmentation value	ppr
0106	1	Pulse mode	1 is pulse + direction mode, 2 is double pulse mode	1-2
0108	1	error code	Please refer to the alarm code for details, and display "0" for no fault	-
0109	1	Operating status	Drive running status, content indicator flashing description	-
0110	1	hardware version	Drive hardware version	-
0111	1	Software version	Drive software version	-
0117	2	current position	Target location	pulse
0119	1	Actual speed display	-	0.01rps

4.2 Basic Parameter Setting (Class 02)

adr	word	content	Elaborate	Range / unit
0201	1	Motor direction switching	Select the motor running direction	0 ~ 1
0213	1	Half-flow ratio	Stop current ratio (Default : 50)	10%~100%
0224	1	Angular filtering	The smaller the value, the smoother the motor runs, but the higher the delay	1~700
0234	1	Digital filtering	Filter coefficient of input pulse. The larger the value, the lower the input frequency response.	1~15
0241	1	Input Current	Set current	5600 0.1%A
0242	2	Set up segmentation	Pulses per revolution	200~102400 ppr
0244	1	Pulse mode	1: Pulse + direction mode 2: Double pulse mode	1~2
0245	1	Half-flow time	Delay time when the motor stops running and enters half flow state (Default : 200ms)	1~32767ms
0296	1	Operation mode selection	0: external pulse 1: Internal pulse Default : 0 Note : After modifying the function, it needs to be powered off and restarted	0~1
0298	1	Mailing address	Default : 1	1~255
0299	2	Baud rate	Default : 19200	1600~115200

4.3 Control Parameter (Class 04)

adr	word	content	Elaborate	Range / unit
0117	2	Current position	Target location	pulse
0119	1	Actual speed display	Display the actual speed after reducing the data by 100 times	0.01rps
0296	1	Operation mode selection	0: external pulse 1: Internal pulse Default : 0 Note : After modifying the function, it needs to be powered off and restarted	0~1
0298	1	Mailing address	Default : 1	1~255
0301	1	Start frequency	Default : 100	1~2000 0.01~20rps
0302	1	Stop frequency	Default : 100	1~2000 0.01~20rps
0303	1	Acceleration	Default : 500	5~10000 rps ²
0304	1	Deceleration	Default : 500	5~10000 rps ²
0305	1	Home mode	Return to origin mode, 0: Return to origin clockwise	0~1

			1: Return to the origin counterclockwise	
0306	1	Fixed-length running speed	Default : 100	1~5000 0.01~50rps
0307	1	Speed mode operating speed	In speed mode, the running direction is consistent with the speed direction Default: 1000	-5000~5000 -50~50rps
0308	1	Jog running speed	Default : 1000	1~5000 0.01~50rps
0309	1	Return to origin running speed	Default : 1000	1~5000 0.01~50rps
0310	1	Creeping speed	Running speed after hitting the origin Default: 1000	1~5000 0.01~50rps
0311	2	Home offset	Default: 0	-2000000000~ 2000000000 pulse
0313	2	Output pulse	Running stroke Absolute position mode: run to the specified position Relative position mode: travel setting offset stroke Default: 0	-2000000000~ 2000000000 pulse
0315	2	Impedance width	Reaching the target position and approaching the distance, outputting the arrival signal Default: 0	-2000000000~ 2000000000 pulse
0317	2	Positive soft limit	Default: 2000000000	-2000000000~ 2000000000 pulse
0319	2	Negative soft limit	Default: -2000000000	-2000000000~ 2000000000 pulse
0321	2	Set current position	Default: 0	-2000000000~ 2000000000 pulse
0323	1	control commands	0: empty 1: Absolute running, running to the set distance, running direction is determined by distance plus or minus, speed plus or minus value is invalid, it is effective to modify target position during running 2: Relative running, running at a set distance and running speed. The running direction is determined by the distance plus or minus. The speed plus or minus value is invalid. Modifying the movement distance during running is invalid 3: Speed mode 4: Jog forward 5: Reverse jog 6: Deceleration and stop 7: Emergency stop 8: Set the current position, which can only be set when the motor is stopped 12: Back to origin 13: Alarm clear 20: Enable Default: 0	0~29

4.4 Input Block Designation (Class 05)

adr	word	content	Elaborate	Range / unit
0400	1	IN1 function selection	0: empty 1: Absolute running, running to the set distance, running direction is determined by distance plus or minus, speed plus or minus value is invalid, it is effective to modify target position during running 2: Relative running, running at a set distance and running speed. The running direction is determined by the distance plus or minus. The speed plus or minus value is invalid. Modifying the movement distance during running is invalid 3: Speed mode 4: Jog forward 5: Reverse jog 6: Deceleration and stop 7: Emergency stop 8: Set the current position, which can only be set when the motor is stopped 9: positive limit 10: Negative limit 11: Origin signal 12: Back to origin 13: Alarm clear 20: Enable Default: 0	0~30
0401	1	IN2 function selection	The setting content is the same as IN1 (default value: 0)	0~30
0402	1	IN3 function selection	The setting content is the same as IN1 (default value: 0)	0~30
0429	1	Universal digital input logic		
0410	1	Pseudo communication settingIN1	0: OFF (initial value 0) 1: ON (trigger the action of IN1 configuration)	0~1
0411	1	Pseudo communication settingIN2	0: OFF (initial value 0) 1: ON (trigger the action of IN1 configuration)	0~1
0412	1	Pseudo communication settingIN3	0: OFF (initial value 0) 1: ON (trigger the action of IN1 configuration)	0~1

5. Appendix

5.1 Alarm Code

Function	Alarm code	Alarm / Warning (Hex/Decimal)	Explanation
Motor overcurrent	Alarm	AH (10)	Motor phase current overcurrent or driver failure
Motor phase loss	Alarm	bH (12)	Motor is not connected
Spare	Alarm	CH (13)	Reserved by the manufacturer
Undervoltage	Alarm	dH (14)	Power input less than 18V
Overvoltage	Alarm	EH (15)	Power input greater than 60V
Overheated	Alarm	FH (16)	The temperature of the driver heat sink reaches above 85 °C
MOS transistor driver voltage fault	Alarm	10H (17)	MOS transistor driver voltage fault
Spare	Alarm	11H (18)	Reserved by the manufacturer
Spare	Alarm	12H (19)	Reserved by the manufacturer
Spare	Alarm	13H (20)	Reserved by the manufacturer
EEPROM data write exception	Alarm	14H (21)	EEPROM data write exception
EEPROM data reading error	Warning	100H (256)	EEPROM data reading error
Bus voltage instability	Warning	200H (512)	Bus voltage instability
Emergency stop	Warning	400H (1024)	Emergency stop
Positive limit	Warning	800H (2048)	On the positive limit or beyond the positive soft limit
Negative limit	Warning	1000H (4096)	On negative limit or beyond negative soft limit
Failed to return to origin	Warning	2000H (8192)	Failed to return to origin



Notes

Multiple warnings can exist simultaneously



Example

Both positive and negative limits are detected simultaneously, with alarm code 1800H (6144)

 +86-0519-8517 7825

 +86-0519-8517 7807

 No. 2850 Luheng Road, Changzhou Economic
Development Zone, Jiangsu Province, China

 www.dingsmotion.com

International Customer

Person in Charge :

Daniel Jang

daniel@dingsmotion.com

No. 2850 Luheng Road, Changzhou
Economic Development Zone,
Jiangsu Province, China

+86-519-85177825, 85177826

North America Customer

Person in Charge :

Nicolas Ha

sales@dingsmotionusa.com

335 Cochrane Circle Morgan Hill,
CA 95037

+1-408-612-4970

China Customer

Person in Charge :

Sweet Shi

info@dingsmotion.com

No. 2850 Luheng Road, Changzhou
Economic Development Zone,
Jiangsu Province, China

+86-519-85177825, 85177826